

PROLIGHT ECO

APE 50 50 PC D S

ARTECH
LIGHTING

Artech Prolight Eco Surface Mounted Luminaire

Artech Prolight Eco architectural LED luminaire with ingress protection IP65. Total luminous flux up to 5040 lm with overall luminaire efficacy up to 105 lm/W. Supplied with fixed output, or optional 3 – hour basic emergency kit. Steel housing with polycarbonate diffuser.

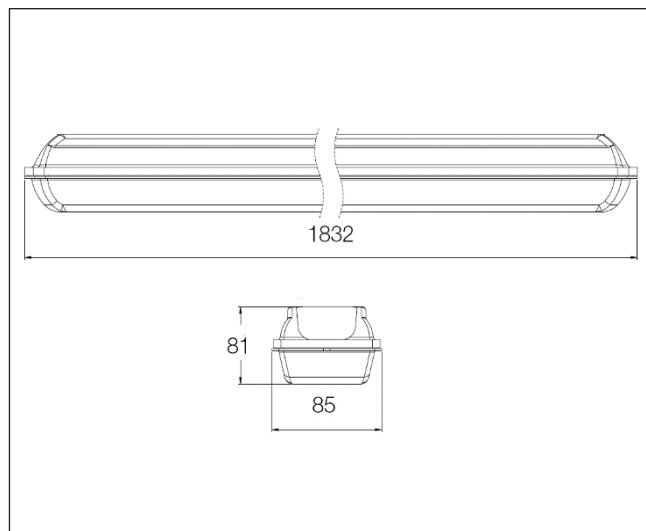

Mounting	Surface
Lamp Type	LED
Wattage	48 W
Lumen Output	5040 lm
Efficacy	105 lm/W
Colour Temperature	5000 K
CRI	80+
Optic	Polycarbonate Diffuser
IP Rating	IP65
Control Gear	Fixed Output
Dimensions	1832 x 85 x 81 mm
Colour Finish	White
MacAdam	3
Service Lifetime	L80/B10-50,000 Hrs

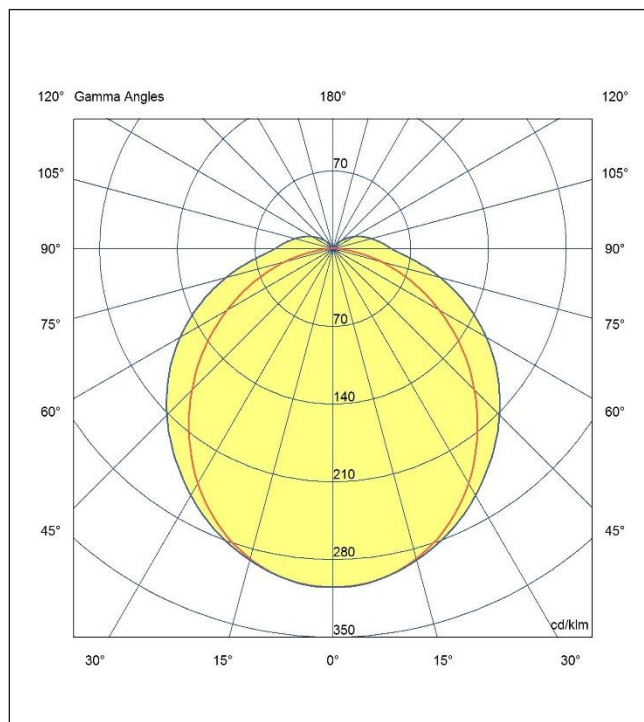

Artech lighting strives to ensure all solutions are supplied with the latest technology, we therefore reserve the right to make technical and design changes without prior notice. Electrical connected load and luminous flux are subject to initial tolerance of up +/- 10%. Colour Temperature is subject to a tolerance of +/-150 Kelvin

St.JohnsRd, Meadowfield Industrial Estate, Durham, Co. Durham, DH78RJ- United Kingdom | T: +44(0)1913787960- F: +44(0)1913787909- www.artechlighting.com

