

# MAGNA HYBRID



Part Code: **MHM 71 27 38 MD**



Artech Magna LED module, with high quality injection moulded TIR optic, COB LED, and extruded aluminium heatsink. Various lumen outputs, beam angles and colour temperatures available. 50mm diameter housing. High luminous efficacy up to 85 lm/W.

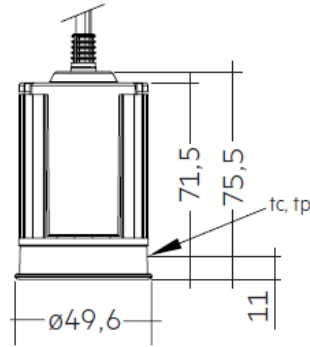

## Production Information

### Physical

Height – 75.5mm  
Diameter – 50mm

### Electrical

Lamp Type - LED  
Wattage – 9.5 W  
Efficacy – 75lm/W  
Control – Mains Dimmable

### LED

Manufacturer – Tridonic  
LED Type – Modula SLA DC G2  
Delivered lumen output – 710lm  
CCT – 2700K  
CRI – 80+  
MacAdam – <3  
Service Lifetime – L80/B10 - 50,000Hrs

### Optic

38° Clear

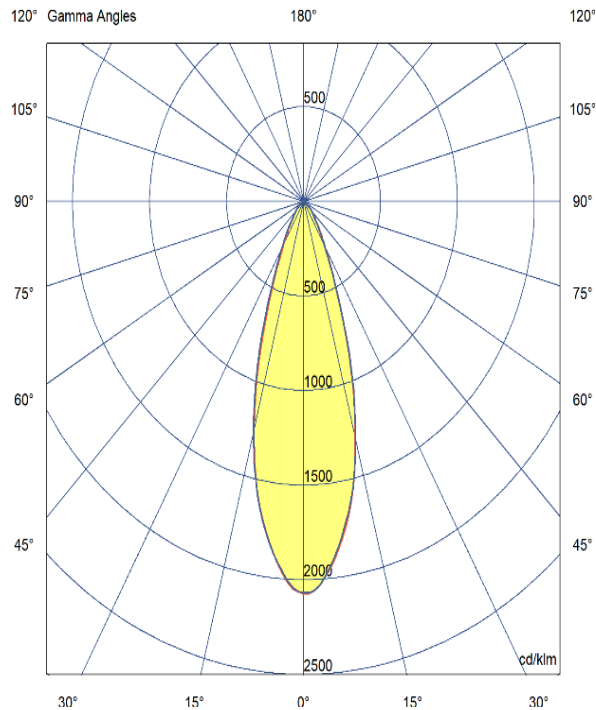

Artech lighting strives to ensure all solutions are supplied with the latest technology, we therefore reserve the right to make technical and design changes without prior notice. Electrical connected load and luminous flux are subject to initial tolerance of up +/- 10%. Colour Temperature is subject to a tolerance of +/-150 Kelvin.

St Johns Rd, Meadowfield Ind. Estate, Durham, Co. Durham, DH7 8RJ, United Kingdom  
T: +44(0) 191 3787960 E: info@artechlighting.com

